

GP 25 M

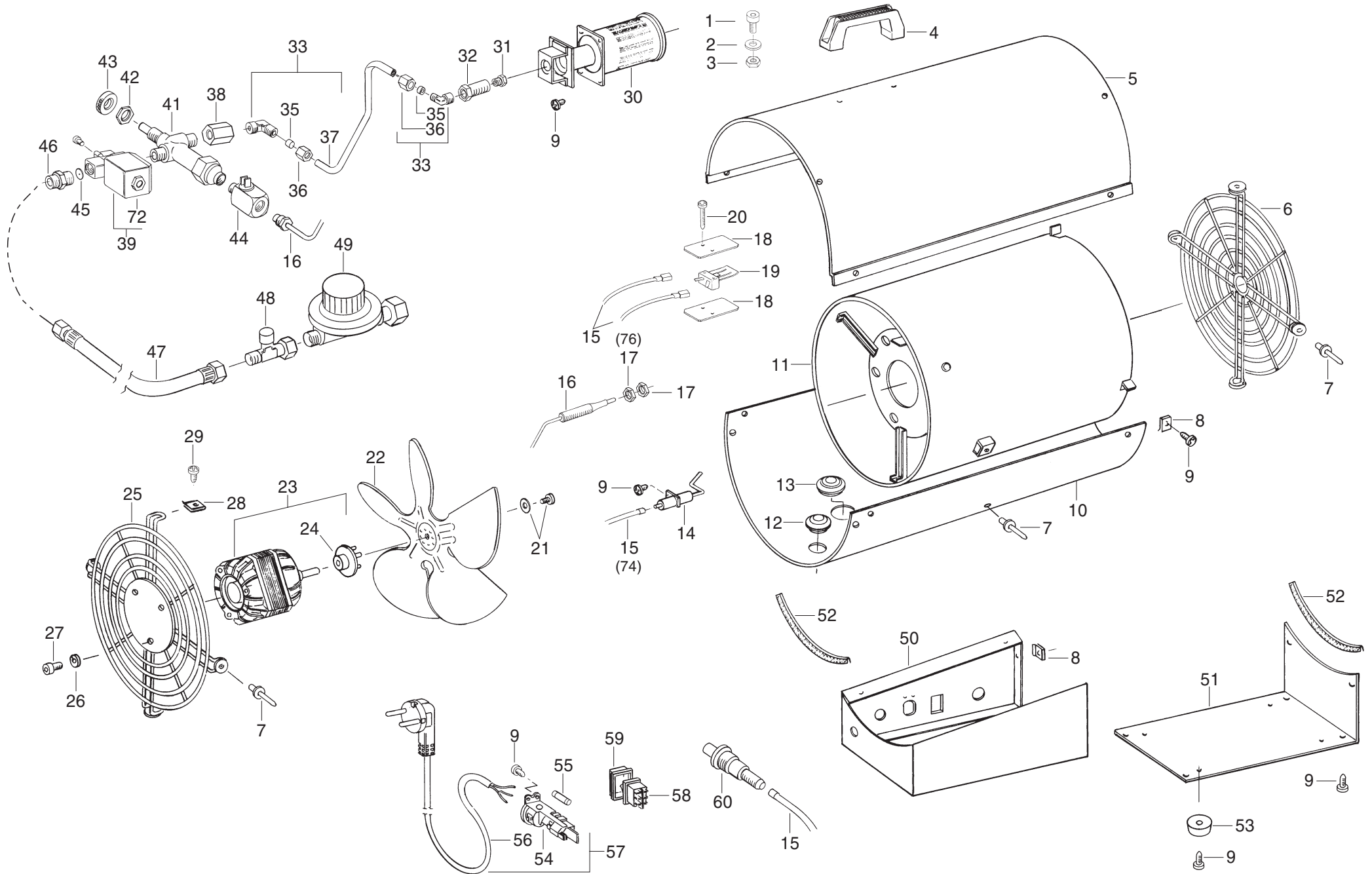

GP 25A	Da matr. n. - De matr. no. - Von masch. nr - From number	41800001	05-99
GP 25M	Da matr. n. - De matr. no. - Von masch. nr - From number	41900001	

Pos.	Cod.	LEGENDA	LEGENDE	NOMENKLATUR	PART LIST	GP 25M	GP 25A
1	M10316	Vite TCEI M 6 x 14	Vite TCEI M 6 x 14	Schraube TCEI M 6 x 14	Screw TCEI M 6 x 14	•	•
2	M20106	Rondella Ø6 x Ø13 x 1,5	Rondelle Ø6 x Ø13 x 1,5	Scheibe Ø6 x Ø13 x 1,5	Washer Ø6 x Ø13 x 1,5	•	•
3	M10704	Dado es. M6	Ecrou M 6	Mutter M 6	Nut M 6	•	•
4	C10202	Maniglia PLnera	Poignée	Handgriff	Handle	•	•
5	G01441R	Scocca superiore	Carrosserie superieur	Haube	Upper body	•	•
6	P30127	Griglia anteriore inox	Grille avant	Ausblasgitter	Outlet grill	•	•
7	M20603	Rivetto Al. Ø4,9 x 9	Rivet Al Ø4,9 x 9	Niet Al Ø4,9 x 9	Al rivet Ø4,9 x 9	•	•
8	M20402	Piastrina doppia U42-032	Plaqué elastique U42-032	Klemmutter U42-032	Elastic plate U42-032	•	•
9	M10508	Vite autofilettante TC 8 x 3/8"	Vis TC 8 x 3/8"	Schraube TC 8 x 3/8"	Screw TC 8 x 3/8"	•	•
10	G01444R	Scocca inferiore	Carrosserie inferieur	Karrosserie unterteil	Lower body	•	•
11	G01447	Camera di combustione	Chambre combustion	Brennkammer	Combustion chamber	•	•
12	C30310	Passacavo Legrand Ø 18	Protection caoutchouc Ø 18	Kabeltülle Ø 18	Protection cable Ø 18	•	•
13	C30311	Passacavo Legrand Ø 35	Protection caoutchouc Ø 35	Kabeltülle Ø 35	Protection cable Ø 35	•	•
14	E10213	Elettrodo accensione	Électrode allumage	Zündelektrode	Ignition electrode	•	•
15	E00138	Cablaggio	Cablage	Kabel	Cable	•	
	E00200	Cablaggio	Cablage	Kabel	Cable		•
16	E50501	Termocoppia gas	Thermocouple	Thermoelement	Thermocouple	•	
17	I31005	Dado M8 per termocoppia	Ecrou M8 pour thermocouple	Mutter M8 für Thermoelement	Nut M8 for thermocouple	•	
18	T10621	Protezione isolante	Protection isolante	Isolierschutz	Insulating profile	•	•
19	E50103	Protettore termico V10C	Thermostat bilame	Sicherheitsthermostat	Overheat thermostat	•	•
20	M10502	Vite autofilettante TC 4 x 3/4"	Vis TC 4 x 3/4"	Schraube TC 4 x 3/4"	Screw TC 4 x 3/4"	•	•
21	M10112	Vite fissaggio ventola EMI	Vis (EMI)	Schraube (EMI)	Screw (EMI)	•	•
22	T30216	Ventola Al VP 254 25°	Ventilateur Ø254 25°	Ventilator Ø254 25°	Fan Ø254 25°	•	•
23	E10535	Motore 82D-2010/1-10 W- 230 V	Moteur 82D-2010/1-10 W- 230 V	Motor 82D-2010/1-10 W- 230 V	Motor 82D-2010/1-10 W- 230 V	•	•
24	C10102	Giunto motore - ventola	Accouplement pl. EMI	Plastkupplung EMI	Plastic coupling EMI	•	•
25	G01178	Griglia aspirazione zn	Grille aspiration	Ansauggitter	Inlet grill	•	•
26	M20301	Rondella grower Ø 4	Rondelle grower Ø 4	Abstandsring grower Ø 4	Washer grower Ø 4	•	•

Pos.	Cod.	LEGENDA	LEGENDE	NOMENKLATUR	PART LIST	GP 25M	GP 25A
27	M10317	Vite TCEI M 4 x 8	Vis M 4 x 8	Schraube M 4 x 8	Screw M 4 x 8	•	•
28	M20412	Piastrina doppia U42-182	Plaque elastique U42-182	Klemmutter U42-182	Elastic plate U42-182	•	•
29	M10505	Vite TC 8 X 1/2"	Vis TC 8 x 1/2"	Schraube TC 8 x 1/2"	Screw TC 8 x 1/2"	•	•
30	T30410	Bruciatore	Brûleur	Brenner	Burner	•	•
31	T30409	Ugello gas Ø 1,0	Gicleur Ø 1,0	Gasdüse Ø 1,0	Nozzle Ø 1,0	•	•
32	I30621	Raccordo portaugello	Raccord pour gicldur	Düse Ekanschluss	Nozzle connection	•	•
33	I30856	Raccordo bicono 90° 1/8"M x 4	Racc. équerre 90° 1/8"M x 4	Eckanschluss 90°1/8"M x 4	Connection 90° 1/8"M x 4	•	•
34	I30863	Raccordo bicono 90° 1/4"M x 4	Racc. équerre 90° 1/4"M x 4	Eckanschluss 90° 1/4"M x 4	Connection 90° 1/4"M x 4		•
35	I30858	Bicono Ø 4	Bicône Ø 4	Doppelkegelring Ø 4	Bicone Ø 4	•	•
36	I30857	Dado per bicono Ø 4	Ecrou pour bicône Ø 4	Mutter für Doppelkegelring Ø 4	Nut for bicone Ø 4	•	•
37	G01388	Tubo rame sagomato Ø 4	Tuyau cuivre Ø 4	Gaszuführrohr Ø 4	Gas supply pipe Ø 4	•	•
38	I30629	Raccordo 1/4"F-1/8"F	Raccord 1/4" F - 1/8" F	Anschluss 1/4" F - 1/8" F	Connection 1/4" F - 1/8" F	•	
39	T30203	Elettrovalvola gas 1/4" V220-50	Electrovanne V220-50	Magnetventil V220-50	Solenoid valve V220-50	•	•
40	I20314	Vite doppia 1/4" M - M	Vis 1/4 M - M	Schraube 1/4 M - M	Screw 1/4 M - M		•
41	T30313	Valvola gas termica	Vanne thermique	Thermoverventil	Thermocouple	•	
42	T30315	Dado M12	Ecrou M12	Mutter M12	Nut M12	•	
43	T30314	Ghiera cromata	Frette	Zwinge	Bush	•	
44	T30325	Disgiuntore termico	Disjointer de thermocouple	Abschalter für thermoelement	Breaker circuit thermoelement	•	
45	I30640	Diaframma OT Ø 1,1	Diaphragme Ø 1,1	Düse Ø 1,1	Diaphragm Ø 1,1	•	•
46	I30639	Raccordo OT 1/4M dx-1/4M sx	Raccord 1/4M dx-1/4M sx	Anschluss 1/4M dx-1/4M sx.	Connection 1/4M dx-1/4M sx	•	•
47	I40554	Tubo gas 1,5 m-1/4F sx-3/8F sx	Tuyau du gaz 1/4F sx-3/8F sx	Gasschlauch 1/4F sx-3/8F sx	Gas hose 1/4F sx- 3/8F sx	•	•
48	T30307	Valvola "stop-gas" 6 kg	Sécurité stop-gaz 6 kg	Schlauchbruchsicherung 6 kg	Excess flow valve 6 kg	•	•
49	T30302-*	Regolatore gas 0,5 - 2 bar	Manodetendeur 0,5 - 2 bar	Druckregler 0,5 - 2 bar	Pressure regulator 0,5 - 2 bar	•	•
50	G01449G	Basamento	Base	Kastenträger	Base	•	
	G01450G	Basamento	Base	Kastenträger	Base		•
51	G01452G	Portello quadro elettrico	Couvercle coffret électrique	Inspectiondeckel	Inspection door	•	•
52	C30408	Profilo gomma a "V"	"V" joint	Gummidichtung "V"	"V" seal	•	•
53	C30308	Tappo antivibrante Ø 19x10	Bouchon	Gummifuss	Plug	•	•

Pos.	Cod.	LEGENDA	LEGENDE	NOMENKLATUR	PART LIST	GP 25M	GP 25A
54	E20307	Morsettiera fissacavo	Presse câble	Kabel Führung	Cable fastener	•	•
55	E10306	Fusibile 4 A	Fusible 4 A	Sicherung 4 A	Fuse 4 A	•	•
56	E30401	Cavo el. c/spina 3 x 1 - 3 m	Cable avec fiche	Kabel mit steckdose	Electric wire with plug	•	•
57	E30407	Cavo el. c/spina e mors. fissacavo	Câble él. avec fiche et presse câble	Kabel mit steckdose und kabel Führung	El. wire with plug and cable fastener	•	•
58	E10110	Interruttore bipolare 0-1	Interrupteur 0 - I	Schalter 0 - I	Switch 0 - I	•	
59	E20402	Protezione pl. per interruttore	Protection pour interrupteur	Schalterschutz	Switch plastic profile	•	•
60	T30603	Accenditore piezoelettrico	Allumeur électrique	Piezozünder	Piezo-igniter	•	
61	E40201	Apparecchiatura Satronic TFI 812	Coffret Satronic TFI 812	Steuerg. Satronic TFI 812	Ctrl box Satronic TFI 812		•
62	E40202	Base per Satronic TFI 812	Support Satronic TFI 812	Unterlage Satronic TFI 812	Box base Satronic TFI 812		•
63	G01005	Supporto apparecchiatura	Support	Stutze	Support		•
64	E10903	Trasformatore A.T.	Transformateur H.T.	Transformator H.T.	Transformer H.T.		•
65	E10214	Elettrodo ionizzazione	Électrodeonisation	Ionisation elektrode	Ionisation electrode		•
66	E10102	Commutatore I - 0 - II	Interrupteur I - 0 - II	Schalter I - 0 - II	Switch I - 0 - II		•
67	G01453	Supporto quadro elettrico	Support coffret électrique	Steuergeraet halterung	Electrical comp. drawer		•
68	E20305	Morsettiera	Barrette de connection	Klemmreiche	Terminal board		•
69	E20627	Connettore spina 3P + T	Fiche thermostat	Stecker	Thermostat plug		•
70	E20626	Connettore presa 3P + T	Prise thermostat	Steckdose	Thermostat socket		•
71	M10514	Vite TC 4 x 1/2"	Vis TC 4 x 1/2"	Schraube TC 4 x 1/2"	Screw TC 4 x 1/2"		•
72	T30204	Bobina E.V. Parker 220 V	Bobine E.V. Parker 220 V	Spule Parker 220 V	Solenoid spool Parker 220 V		•
73	E11135	Filtro antidisturbo DEM	Filtre antipararites DEM	Funk-enstorfilter DEM	Anti-jamming filter DEM		•
74	E00204	Cavetto accensione	Cable allumage	Zündungskabel	Switching cable		•
	E00148	Cavetto accensione	Cable allumage	Zündungskabel	Switching cable	•	
75	E00203	Cavetto ionizzazione	Cable ionisation	Ionisierungskabel	Ionization cable		•
76	E00184	Cavetto capsula term.	Cable thermostat bilame	Thermokapselkabel	Thermostatic capsule cable	•	
	E00186	Cavetto capsula term.	Cable thermostat bilame	Thermokapselkabel	Thermostatic capsule cable		•
77	E20804	Fascetta plastica	Bande plastique	Rohrklemme	Hose clamp		•

* : I - Italia; F - Francia; D - Germania; GB - Gran Bretagna