

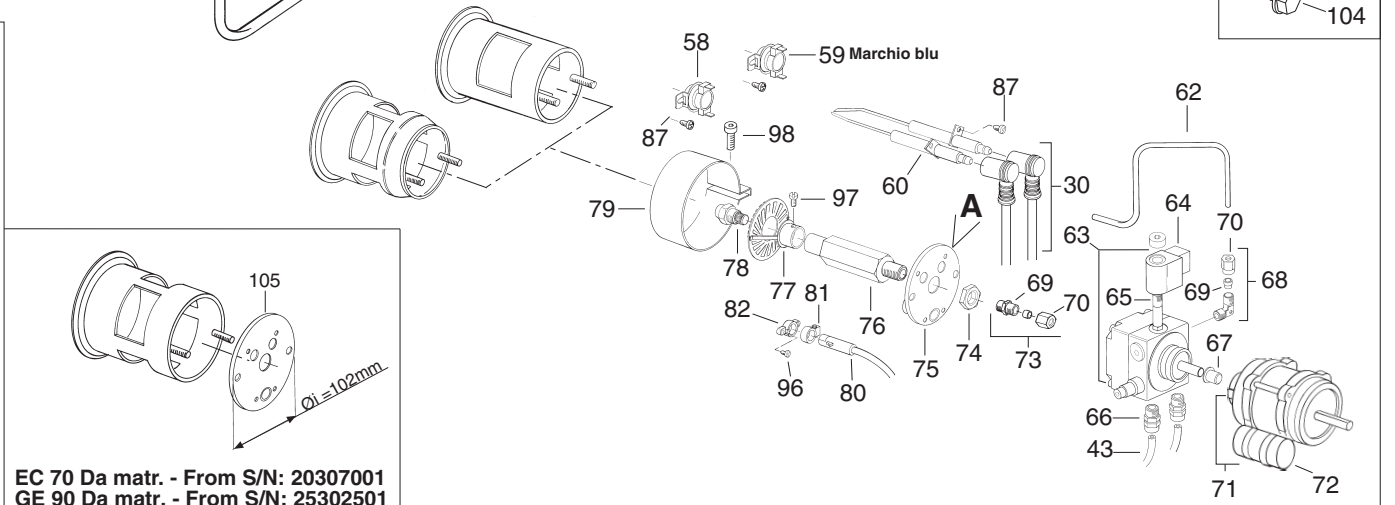

EC 25

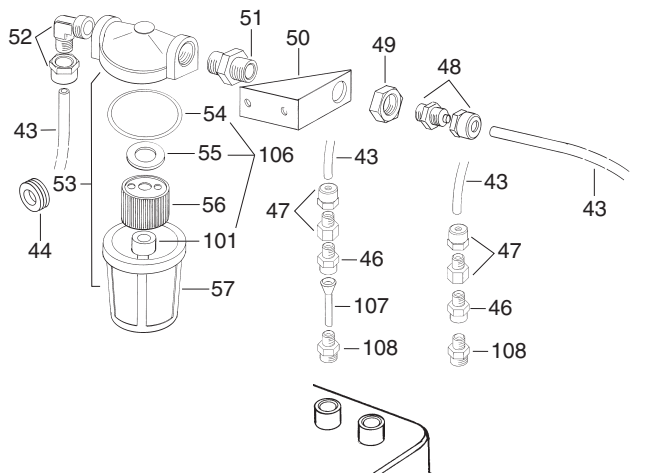
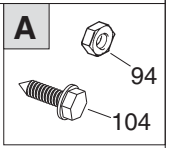
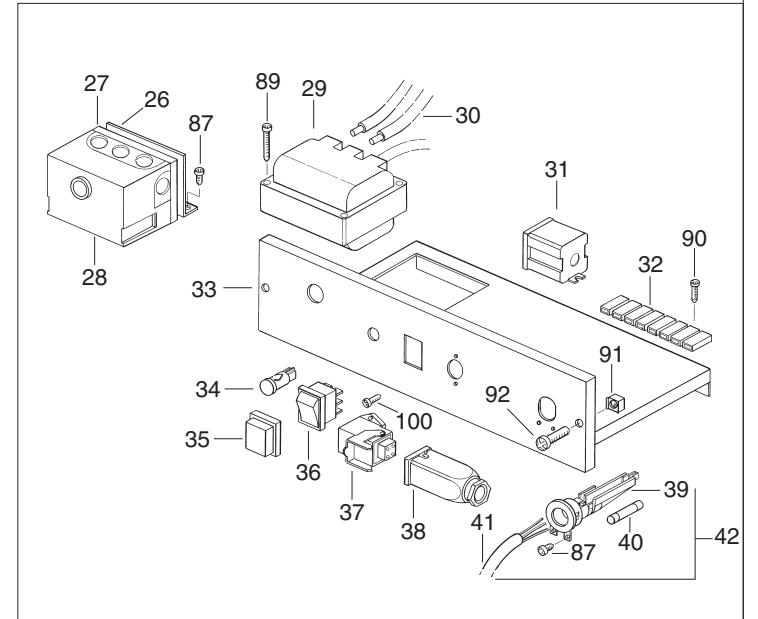
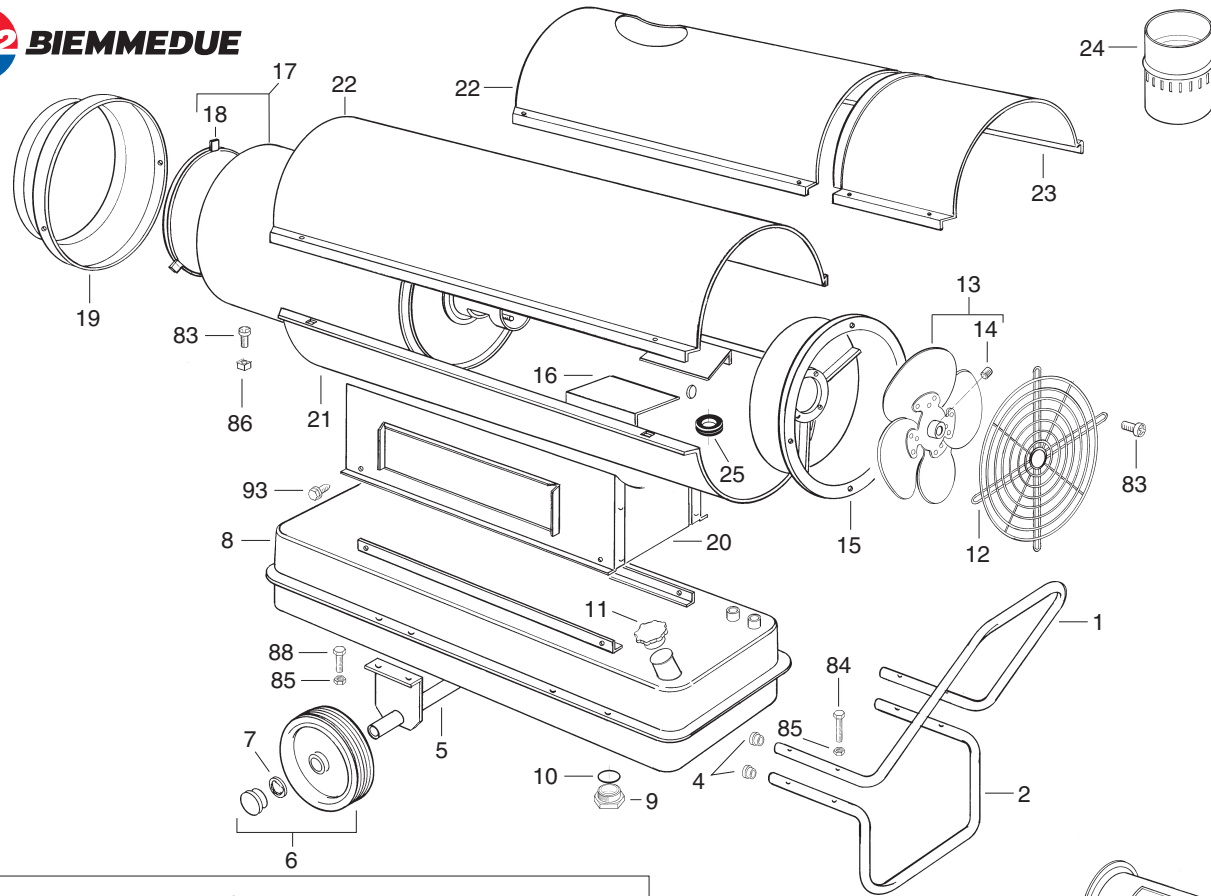

EC 70 Da matr. - From S/N: 20307001
GE 90 Da matr. - From S/N: 25302501

Da matr. N. - De matr. No. - Von Masch. Nr. - From number:

EC 25

20104501

Pos.	Cod.	€		EC 25		LEGENDA	LEGENDE	NOMENKLATUR	PART LIST
01	P20134 P20135			•		Maniglia	Poignée	Handgriff	Handle
02	P20132 P20133			•		Piede	Pied	Fuß	Foot
04	C30305			•		Tappo copritesta	Bouchon	Gummifuss	Plug
05	G01432 G01433			•		Assale	Essieu	Achse	Wheel axle
06	C10509 C10504			•		Ruota Ø 200 - Ø 20 Ruota Ø 250 - Ø 25	Roue Ø 200 - Ø 20 Roue Ø 250 - Ø 25	Rad Ø 200 - Ø 20 Rad Ø 250 - Ø 25	Wheel Ø 200 - Ø 20 Wheel Ø 250 - Ø 25
07	M20203 M20204			•		Rondella elastica Ø 20 Rondella elastica Ø 25	Clips de fixation Ø 20 Clips de fixation Ø 25	Radverschluss Ø 20 Radverschluss Ø 25	Wheel holder Ø 20 Wheel holder Ø 25
08	G06110-7035 G01428 G01471			•		Serbatoio gasolio	Réservoir fuel	Tank	Fuel tank
09	I25020			•		Tappo Serbatoio M16x1,5	Bouchon de vidange	Abluss Propfen Oel	Drain plug
10	C30375			•		OR Ø16 x 2,62	OR Ø16 x 2,62	OR Ø16 x 2,62	OR Ø16 x 2,62
11	C30356			•		Tappo bocchettone	Bouchon	Pfropfen	Drain plug
12	P30103 P30129			•		Griglia aspirazione	Grille aspiration	Ansauggitter	Inlet grill
13	T10207 T10202 T10201			•		Ventola Ø 300 18° Ventola Ø 300 27° Ventola Ø 500 33°	Ventilateur Ø 300 18° Ventilateur Ø 300 27° Ventilateur Ø 500 33°	Ventilator Ø 300 18° Ventilator Ø 300 27° Ventilator Ø 500 33°	Fan Ø 300 18° Fan Ø 300 27° Fan Ø 500 33°
14	M10609			•		Grano M8x8	Vis M8x8	Schraube M8x8	Screw M8x8
15	G01461 G02010 G01515			•		Supporto motore ventola	Bride support moteur	Motor Flansch	Motor flange
16	G01061-1 G02024-1 G01061-2 G02024-2 G01513			•		Convogliatore aria destro	Défecteur droit d'air	Luftleitblech rechts	Right air flap
				•		Convogliatore aria sinistro	Défecteur gauche d'air	Luftleitblech links	Left air flap
				•		Convogliatore aria	Défecteur d'air	Luftleiblech	Air flap
17	G02009 G01434 G01435 G01035			•		Camera di combustione	Chambre de combustion	Brennkammer	Combustion chamber
19	G01463 G01042 G02008			•		Cono diffusore	Embout conique	Ausblaskonus	Outlet cone
20	G01495 G01496 G02014			•		Basamento	Base	Kastenträger	Base
21	G02011 G01498 G01499 G01500			•		Scocca inferiore	Carrosserie inferieur	Untere Karrosserie	Lower body
22	G02012 G01504 G01505 G01506			•		Scocca superiore	Carrosserie superieur	Hohere Karrosserie	Upper body
23	G02013 G01516 G01517			•		Coperchio ispezione	Porte visite	Inspektionsklappe	Cover inspection

Da matr. N. - De matr. No. - Von Masch. Nr. - From number:

EC 25

20104501

Pos.	Cod.	€		EC 25		LEGENDA	LEGENDE	NOMENKLATUR	PART LIST
24	G01044			•		Raccordo camino Ø 150	Cheminée Ø 150	Kamin Ø 150	Chimney Ø 150
25	C30307			•		Protezione cavo Ø35	Protection cable Ø35	Kabelschutz Ø35	Cable protection Ø35
26	G01005			•		Angolare supporto	Support	Stütze	Support
27	E40107			•		Base per LOA21/24	Support LOA21/24	Steuergerätunterlage	LOA21/24 base
28	E40106			•		Apparecchiatura Landis & Gyr LOA21-24	Coffret Landis & Gyr LOA21-24	Steuergerät Landis & Gyr LOA21-24	Control box /Landis & Gyr LOA21-24
29	E10917			•		Trasformatore A.T. 818C 230V	Transformateur H.T. 818C 230V	Zündtrafo H.T. 818C 230V	Transformer H.T. 818C 230V
30	G02044			•		Cavo accensione	Cable allumage	Zündungskabel	Switching cable
31	E11120			•		Relè Finder 65.31 V 230	Relais Finder 65.31 V 230	Relais Finder 65.31 V 230	Relay Finder 65.31 V 230
32	E20305			•		Morsettiera	Barrette de connection	Klemme	Terminal board
33	G01518			•		Supporto quadro elettrico	Support coffret électrique	Steuergerät halterung	Support components drawer
34	E11021			•		Lampada 230V	Lampe Témoins 230V	Kontrolllampe 230V	Pilot lamp 230V
35	E20402			•		Protezione interruttore	Protection interrupteur	Schalterabdeckung	Switch cover
36	E10110			•		Interruttore	Interrupteur	Schalter	Switch
37	E20626			•		Connettore presa 3P + T	Fiche thermostat 3P + T	Thermostat stecker 3P + T	Thermostat plug 3P + T
38	E20627			•		Connettore spina 3P + T	Plaque de prise 3P + T	Steckdose platte 3P + T	Plate plug 3P + T
39	E20307			•		Morsetto fissacavo	Presse câble	Kabel Führung	Cable fastener
40	E10307			•		Fusibile vetro (6x30) 6A	Fusible (6x30) 6A	Sicherung (6x30) 6A	Fuse (6x30) 6A
	E10308			•		Fusibile vetro (6x30) 10A	Fusible (6x30) 10A	Sicherung (6x30) 10A	Fuse (6x30) 10A
41	E30401			•		Cavo elettrico con spina	Cable électrique avec fiche	Elektro kabel mit steckdose	Electric wire with plug
42	E30407			•		Cavo elettrico c/spina e morsetto fissacavo	Câble électrique avec fiche et presse câble	Elektro kabel mit steckdose und kabel Führung	Electric wire with plug and cable fastener
43	I40303			•		Tubo Rilsan Ø 6	Tuyau Rilsan Ø 6	Rilsan Rhor Ø 6	Rilsan pipe Ø 6
44	C30301			•		Protezione cavo Ø 18	Protection cable Ø 18	Kabelschutz Ø 18	Cable protection Ø 18
46	EC.0020720			•		Raccordo diritto 1/4"F - 3/8"M	Raccord droit 1/4"F - 3/8"M	Anschluss 1/4"F - 3/8"M	Connection Straight 1/4"F - 3/8"M
47	I20426			•		Raccordo diritto 3/8" Fx6	Raccord droit 3/8" Fx6	Anschluss 3/8" Fx6	Connection Straight 3/8" Fx6
48	I20402			•		Raccordo diritto Ø6 1/8"M	Raccord droit Ø6 1/8"M	Anschluss Ø6 1/8"M	Connection Straight Ø6 1/8"M
49	I31017			•		Controdado 3/8"x5	Ecrou 3/8"x5	Mutter 3/8"x5	Nut 3/8"x5
50	K01010			•		Angolare supporto filtro	Support filtre	Filterhalterung	Filter support
51	I31013			•		Vite doppia 3/8" MM	Vis double 3/8" MM	Doppelte Schraube 3/8" MM	Double screw 3/8" MM
52	I20405			•		Raccordo 90° Ø6 1/8"M	Raccord 90° Ø6 1/8"M	Eckanschluss 90° Ø6 1/8"M	Connection 90° Ø6 1/8"M
	I20403			•		Raccordo diritto Ø6 3/8"M	Raccord droit Ø6 3/8"M	Anschluss Ø6 3/8"M	Connection Straight Ø6 3/8"M
53	T20211			•		Filtro gasolio 3/8"	Filtre gasoil 3/8"	Heizölfilter 3/8"	Oil filter 3/8"
54	T20202			•		OR filtro	OR du filtre	OR Filter	Filter OR
55	T20214			•		Guarnizione superiore filtro	Joint superieur du filtre gasoil	Obere Oelfilterdichtung	Upper oil filterseal
56	T20206			•		Cartuccia filtro	Cartouche filtre	Filterelement	Filter cartridge
57	T20212			•		Bicchiera filtro	Cuve filtre	Filtergehäuse	Filter housing
58	E50101			•		Capsula termostatica Fan	Thermostat bilame Fan	Thermostat Fan	Fan Thermostat
59	E50102			•		Capsula termostatica Limit	Thermostat bilame Limit	Thermostat Limit	Limit Thermostat
60	E10215			•		Elettrodo	Électrode	Elektrode	Electrode
62	G01512			•					
	G01863			•		Tubo sagomato Ø 4	Tuyau Ø 4	Ölzufuhrrohr Ø 4	Oil supply pipe Ø 4
63	T20410			•		Pompa Danfoss BFP11/21-R3	Pompe Danfoss BFP11/21-R3	Pumpe Danfoss BFP11/21-R3	Pump Danfoss BFP11/21-R3
	T20411			•		Pompa Danfoss BFP11/21-R5	Pompe Danfoss BFP11/21-R5	Pumpe Danfoss BFP11/21-R5	Pump Danfoss BFP11/21-R5
64	T20114			•		Bobina elettrovalvola BFP11/21	Bobine electrovanne BFP11/21	Spule Magnetventil BFP11/21	Solenoid spool BFP11/21
65	T20117			•		Corpo elettrovalvola Danfoss	Corps electrovanne Danfoss	Körper Magnetventil Danfoss	Solenoid valve (body) Danfoss
66	I20401			•		Raccordo diritto Ø6 1/4"M	Raccord droit Ø6 1/4"M	Anschluss Ø6 1/4"M	Connection Straight Ø6 1/4"M
67	E10513			•		Giunto plastica K1	Accouplement plastique K1	Plastkupplung K1	Plastic coupling K1
	E10514			•		Giunto plastica K2	Accouplement plastique K2	Plastkupplung K2	Plastic coupling K2
68	I30856			•		Raccordo 90° 1/8"M per bicono Ø4	Raccord 90° 1/8"M pour bicone Ø4	Anschluss 90° 1/8"M für Ø4	Connection 90° 1/4"M for bicone Ø4
69	I30858			•		Bicono Ø 4	Bicône Ø 4	Doppelkegelring Ø 4	Bicone Ø 4
70	I30857			•		Dado per bicono Ø 4	Ecrou pour raccord Ø 4	Mutter für Doppel. Ø 4	Nut for bicone Ø 4

Da matr. N. - De matr. No. - Von Masch. Nr. - From number:

EC 25

20104501

Pos.	Cod.	€		EC 25		LEGENDA	LEGENDE	NOMENKLATUR	PART LIST
71	E10511 E10546 E10515			•		Motore 130W con condensatore Motore 200W con condensatore Motore 750W con condensatore	Moteur 130W avec condensateur Moteur 200W avec condensateur Moteur 750W avec condensateur	Motor 130W mit Kondensator Motor 200W mit Kondensator Motor 750W mit Kondensator	Motor 130W with capacitor Motor 200W with capacitor Motor 750W with capacitor
72	E11201 E11214 E11202			•		Condensatore 5 µF Condensatore 6,3 µF Condensatore 16 µF	Condensateur 5 µF Condensateur 6,3 µF Condensateur 16 µF	Kondensator 5 µF Kondensator 6,3 µF Kondensator 16 µF	Capacitor 5 µF Capacitor 6,3 µF Capacitor 16 µF
73	I30859			•		Raccordo diritto 1/8"M per bicono Ø4	Raccord droit 1/8"M pour bicone Ø4	Anschluss 1/8"M für Doppelkegelring Ø4	Connection Straight 1/8"M for bicone Ø4
74	I31034			•		Controdado M14	Ecrou M14	Mutter M14	Nut M14
75	G01176			•		Flangia supporto bruciatore Ø 80mm	Bride Brûleur Ø 80mm	Brenner Flansch Ø 80mm	Burner flange Ø 80mm
76	I30638			•		Canotto portaugello	Support gicleur	Düsehalter	Nozzle support
77	G01077			•		Deflettore centrato	Accroche flamme	Stauscheibe	Turbo disc
78	T20329 T20301 T20303 T20305			•		Ugello 0,50 GPH 80° H Ugello 0,65 GPH 80° S Ugello 1,00 GPH 80° S Ugello 1,50 GPH 80° S	Gicleur 0,50 GPH 80° H Gicleur 0,65 GPH 80° S Gicleur 1,00 GPH 80° S Gicleur 1,50 GPH 80° S	Düse 0,50 GPH 80° H Düse 0,65 GPH 80° S Düse 1,00 GPH 80° S Düse 1,50 GPH 80° S	Nozzle 0,50 GPH 80° H Nozzle 0,65 GPH 80° S Nozzle 1,00 GPH 80° H Nozzle 1,50 GPH 80° H
79	G01045 G01047			•		Anello regolazione aria	Volet réglage air	Brennluftklappe	Air regulatoin flap
80	E50306			•		Fotoresistenza LOA21/24	Photoresistance LOA21/24	Fotozelle LOA21/24	Photoresistance LOA21/24
81	E50307			•		Anello fotoresistenza	Boucle de fixation	Fotozelle Tragbuechse	Fixing clamp
82	E50308			•		Flangia fotoresistenza	Bride photoresistance	Fotozelle Flansch	Photoresistance flange
83	M10108			•		Vite TC M5x16	Vis TC M5x16	Schraube TC M5x16	Screw TC M5x16
84	M10229			•		Vite TE M6x55	Vis TE M6x55	Schraube TE M6x55	Screw TE M6x55
85	M10704			•		Dado M6	Ecrou M6	Mutter M6	Nut M6
86	M20408			•		Dado in gabbia M5	Écrou prisonnier M5	Käfigmutter M5	Anchor nut M5
87	M10508			•		Vite autofil TC 8x3/8"	Vis TC 8x3/8"	Schraube TC 8x3/8"	Screw TC 8x3/8"
88	M10204			•		Vite TE M6x16	Vis TE M6x16	Schraube TE M6x16	Screw TE M6x16
89	M10507			•		Vite autofil TC 8x1" 1/2"	Vis TC 8x1"1/2"	Schraube TC 8x1"1/2"	Screw TC 8x1"1/2"
90	M10514			•		Vite autofil TC 4x1/2"	Vis TC 4x1/2"	Schraube TC 4x1/2"	Screw TC 4x1/2"
91	M20409			•		Dado in gabbia M6	Écrou prisonnier M6	Käfigmutter M6	Anchor nut M6
92	M10115			•		Vite TC M6x20	Vis TC M6x20	Schraube TC M6x20	Screw TC M6x20
93	M10509			•		Vite autofil TE 14x1/2"	Vis TE 14x1/2"	Schraube TE 14x1/2"	Screw TE 14x1/2"
94	M10703			•		Dado M5	Ecrou M5	Mutter M5	Nut M5
96	M10504			•		Vite autofil TC 6x1/2"	Vis TC 6x1/2"	Schraube TC 6x1/2"	Screw TC 6x1/2"
97	M10102			•		Vite TC M4x8	Vis TC M4x8	Schraube TC M4x8	Screw TC M4x8
98	M10312			•		Vite TCEI M6x25	Vis TCEI M6x25	Schraube TCEI M6x25	Screw TCEI M6x25
100	M10501			•		Vite autofil TC 4x3/8"	Vis TC 4x3/8"	Schraube TC 4x3/8"	Screw TC 4x3/8"
101	T20213			•		Guarnizione inferiore filtro	Joint inferieur du filtre gasoil	Untere Oelfilterdichtung	Lower oil filter seal
104	M10517			•		Vite autofil TE 10x5/8"	Vis TE 10x5/8"	Schraube TE 10x5/8"	Screw TE 10x5/8"
105	G01890			•		Flangia supporto bruciatore Ø 102mm	Bride Brûleur Ø 102mm	Brenner Flansch Ø 102mm	Burner flange Ø 102mm
106	T20234			•		Kit OR filtro gasolio	KIT OR filtre gasoil	Kit OR heizölfilter	OR KIToil filter
107	I30696			•		Pescante L.220mm	Pascante L.220mm	Pascante L.220mm	Pascante L.220mm
108	I30737			•		Nipplo OT 1/4" M - M12x1,75 M	Nipplo OT 1/4" M - M12x1,75 M	Nipplo OT 1/4" M - M12x1,75 M	Nipplo OT 1/4" M - M12x1,75 M